

CA-1112 R

CTCSS TONE ENCODER

GENERAL DESCRIPTION

The Maxon CA-1112C/R is a new concept in programmable CTCSS tone encoders. Any tones between 67 Hz and 250.3 Hz ($\pm .01$ Hz) can be programmed into the CA-1112C and any tones between 67 Hz and 203.5 Hz ($\pm .01$ Hz) can be programmed into the CA-1112R.

Once the unit is programmed, the tones contained in memory are user selected by means of pads on the PCB. The tone output is low distortion sine wave, with a variable amplitude of 0 to 2 volts p-p. The CA-1112C B+ is 5 volts and the CA-1112R is 10 volts.

PROGRAMMING

This programmable line of products uses solder bridges from the pads to the Ground Buss to select the frequency desired. When the jumpers are in place, the binary code that is presented to IC1 internally selects which one of the frequencies is to be generated by the encoder.

The CA-1112R is programmed by jumpering from Programming Pads 5,4,3,2 and 1 to the Ground Buss and the CA-1112C is programmed by jumpering from Programming Pads 1,2,3,4,5, and 6 to the Ground Buss to select the frequency desired. For instance for the CA-1112R, if 1Z (100.0 Hz) is desired, the code required is located on the Programming Chart and the jumpers are added accordingly. For example, the code for 1Z is "01011" thus 5 and 3 are grounded to the Ground Buss and 4,2 and 1 are left unconnected.

INSTALLATION

1. Connect the CA-1112C/R to the Main PCB. Refer to the Wiring Diagram for connection details.
2. Peel the protective backing from the double sided tape on the CTCSS Board. Install the CTCSS Board (using the mounting tape) into the compartment located in the top of the back cabinet assembly.

ALIGNMENT

1. Program the CA-1112C/R to the correct tone frequency referring to the Programming Chart.
2. Connect an RF dummy load and a coupler (or power attenuator) to the antenna connector. Connect a deviation meter to the coupled or attenuated output.
3. Key the radio transmitter and adjust RV1 on the CA-1112C or R4 on the CA-1112R for 750Hz deviation as shown on the deviation meter. There should be no audio to the microphone input of the radio during this adjustment.
4. Recheck the deviation on the voice signals using the alignment procedure outlined in the Transmitter Alignment Section of the Service Manual.

CA-1112 R

CTCSS TONE ENCODER

CA-1112R PCB

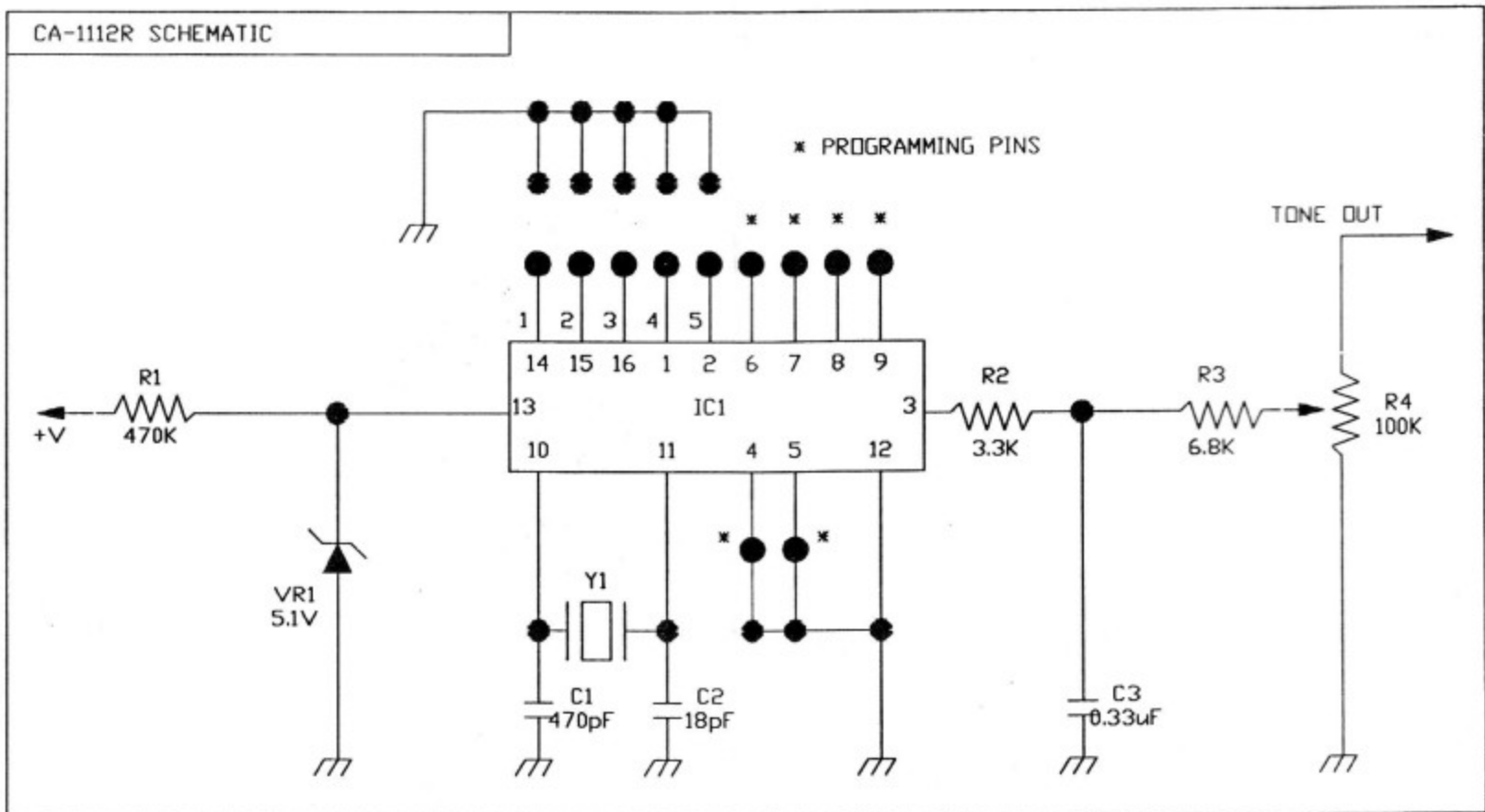
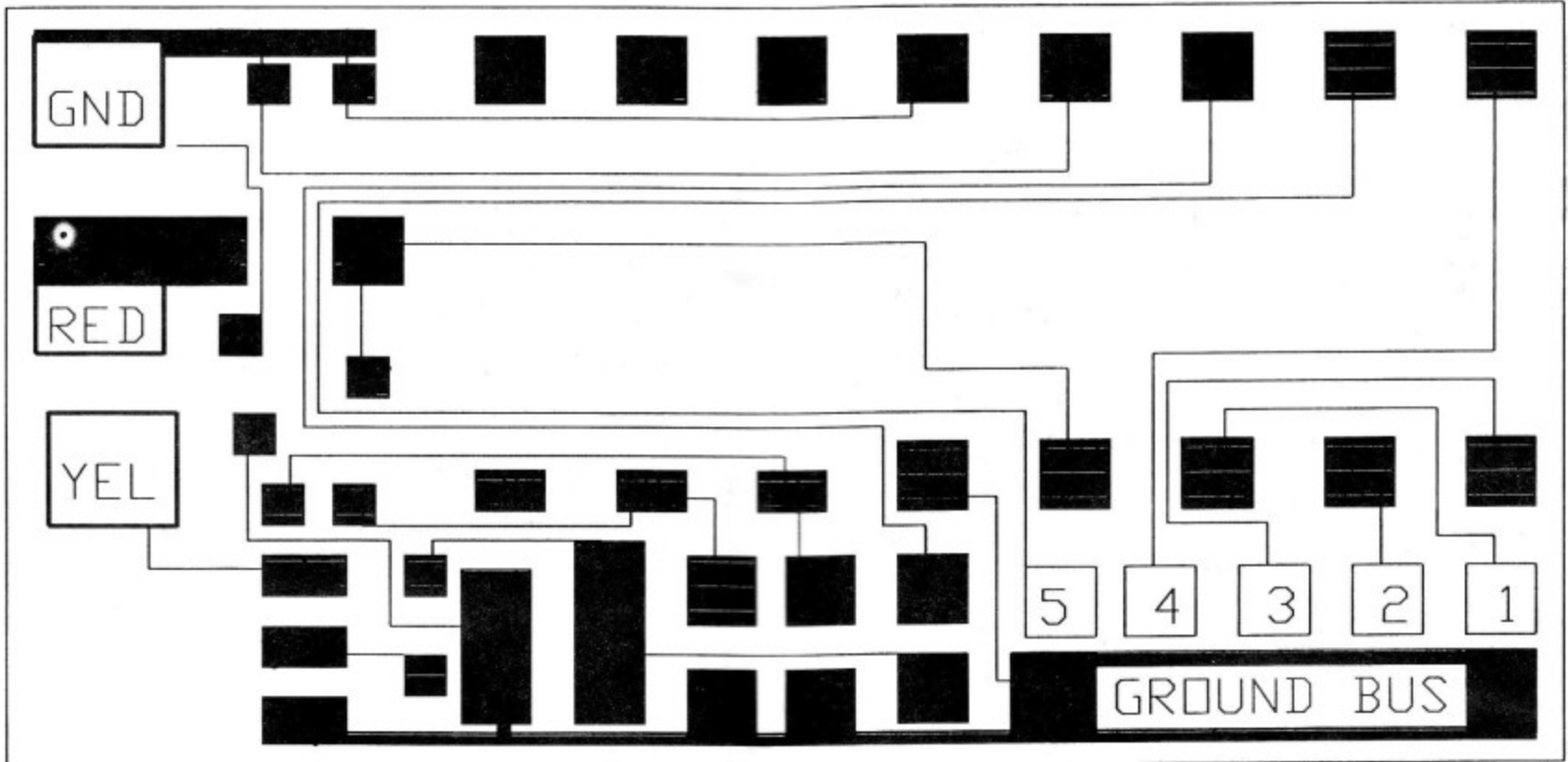

CA-1112R SCHEMATIC

PROGRAMMING CHART FOR THE CA-1112R

NUMBER	CODE	FREQUENCY	PROGRAM LINES				
			5	4	3	2	1
1	XZ	67.0	0	0	0	0	0
2	XA	71.9	0	0	0	0	1
3	WA	74.4	0	0	0	1	0
4	XB	77.0	0	0	0	1	1
5	SP	79.7	0	0	1	0	0
6	YZ	82.5	0	0	1	0	1
7	YA	85.4	0	0	1	1	0
8	YB	88.5	0	0	1	1	1
9	ZZ	91.5	0	1	0	0	0
10	ZA	94.8	0	1	0	0	1
11	ZB	97.4	0	1	0	1	0
12	1Z	100.0	0	1	0	1	1
13	1A	103.5	0	1	1	0	0
14	1B	107.2	0	1	1	0	1
15	2X	110.9	0	1	1	1	0
16	2A	114.8	0	1	1	1	1
17	2B	118.8	1	0	0	0	0
18	3Z	123.0	1	0	0	0	1
19	3A	127.3	1	0	0	1	0
20	3B	131.8	1	0	0	1	1
21	4Z	136.5	1	0	1	0	0
22	4A	141.3	1	0	1	0	1
23	4B	146.2	1	0	1	1	0
24	5Z	151.4	1	0	1	1	1
25	5A	156.7	1	1	0	0	0
26	5B	162.2	1	1	0	0	1
27	6Z	167.9	1	1	0	1	0
28	6A	173.8	1	1	0	1	1
29	6B	179.9	1	1	1	0	0
30	7Z	186.2	1	1	1	0	1
31	7A	192.8	1	1	1	1	0
32	M1	203.5	1	1	1	1	1